



SANYO Semiconductors

DATA SHEET

LA42105 — Monolithic Linear IC Audio Output for TV application BTL 5W × 1ch Power Amplifier

Overview

The LA42105 is a 5W 1-channel power amplifier IC and optimal for use as the audio output power amplifier in TV application

Functions

- 5W × 1 channels ($V_{CC} = 9.5V$, $R_L = 8\Omega$, THD = 10%)
- Built-in standby function.
- Built-in mute function.
- Built-in various protection circuit (short to power/short to ground/load shorting/thermal).

Specifications

Maximum Ratings at $T_a = 25^\circ C$

Parameter	Symbol	Conditions	Ratings	Unit
Maximum supply voltage	V_{CC} max	No signal	16	V
Allowable power dissipation	P_d max	Infinitely large heat sink	30	W
Maximum output current	I_O peak		1.0	A
Maximum junction temperature	T_j max		150	$^\circ C$
Thermal resistance	θ_{jc}		2.5	$^\circ C/W$
Operating temperature	T_{opr}		-20 to +75	$^\circ C$
Storage temperature	T_{stg}		-40 to +150	$^\circ C$

Operating Conditions at $T_a = 25^\circ C$

Parameter	Symbol	Conditions	Ratings	Unit
Recommended supply voltage	V_{CC}		9.5	V
Recommended load resistance	R_L		8	Ω
Allowable operating supply voltage range	V_{CC} op	Under conditions such that maximum ratings are not exceeded	7 to 14	V

■ Any and all SANYO Semiconductor Co.,Ltd. products described or contained herein are, with regard to "standard application", intended for the use as general electronics equipment (home appliances, AV equipment, communication device, office equipment, industrial equipment etc.). The products mentioned herein shall not be intended for use for any "special application" (medical equipment whose purpose is to sustain life, aerospace instrument, nuclear control device, burning appliances, transportation machine, traffic signal system, safety equipment etc.) that shall require extremely high level of reliability and can directly threaten human lives in case of failure or malfunction of the product or may cause harm to human bodies, nor shall they grant any guarantee thereof. If you should intend to use our products for applications outside the standard applications of our customer who is considering such use and/or outside the scope of our intended standard applications, please consult with us prior to the intended use. If there is no consultation or inquiry before the intended use, our customer shall be solely responsible for the use.

■ Specifications of any and all SANYO Semiconductor Co.,Ltd. products described or contained herein stipulate the performance, characteristics, and functions of the described products in the independent state, and are not guarantees of the performance, characteristics, and functions of the described products as mounted in the customer's products or equipment. To verify symptoms and states that cannot be evaluated in an independent device, the customer should always evaluate and test devices mounted in the customer's products or equipment.

SANYO Semiconductor Co., Ltd.

TOKYO OFFICE Tokyo Bldg., 1-10, 1 Chome, Ueno, Taito-ku, TOKYO, 110-8534 JAPAN

LA42105

Electrical Characteristics at $T_a = 25^\circ\text{C}$, $V_{CC} = 9.5\text{V}$, $R_L = 8\Omega$, $f = 1\text{kHz}$, $R_g = 600\Omega$

Parameter	Symbol	Conditions	Ratings			Unit
			min	typ	max	
Standby current	I_{st}	Amplifier OFF		0	10	μA
Quiescent current	I_{CCO}	$R_g = 0$, $R_L = \text{OPEN}$	25	50	100	mA
Output power	P_O	THD = 10%	4	5		W
Total harmonic distortion	THD	$P_O = 1\text{W}$		0.06	0.2	%
Voltage gain	VG	$V_O = 0\text{dBm}$	30	32	34	dB
Output noise voltage	V_{NO}	$R_g = 0$, BPF = 20Hz to 20kHz		0.2	0.4	mVrms
Ripple rejection ratio	SVRR	$R_g = 0$, $f_R = 100\text{Hz}$, $V_{CCR} = 0\text{dBm}$	40	50		dB
Mute attenuation value	ATT	$V_O = 1\text{Vrms}$, BPF = 20Hz to 20kHz	80	90		dB
Mute control voltage (pin 7)	V_{mute}	Mute ON *1	1.5		3.0	V
		Mute OFF	0		0.5	V
Standby control voltage (pin 6)	V_{st}	Amplifier ON *1	2.5		V_{CC}	V
		Amplifier OFF	0		0.5	V
Input resistance	R_i		21	30	39	$\text{k}\Omega$

*1 : Note that the standby pin (pin 6) and MUTE pin (pin 7) incorporate the anti-electrostatic diode allowing the current to flow through the diode when the potential of V_{CC} (pin 9) decreases below that of pin 6 or 7.

Package Dimensions

unit : mm (typ)

3336

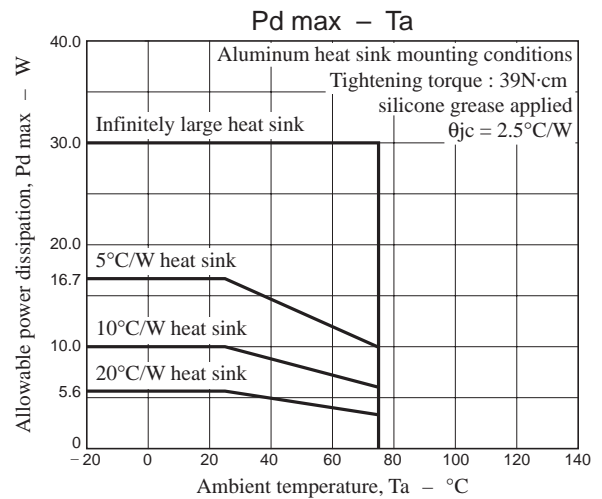
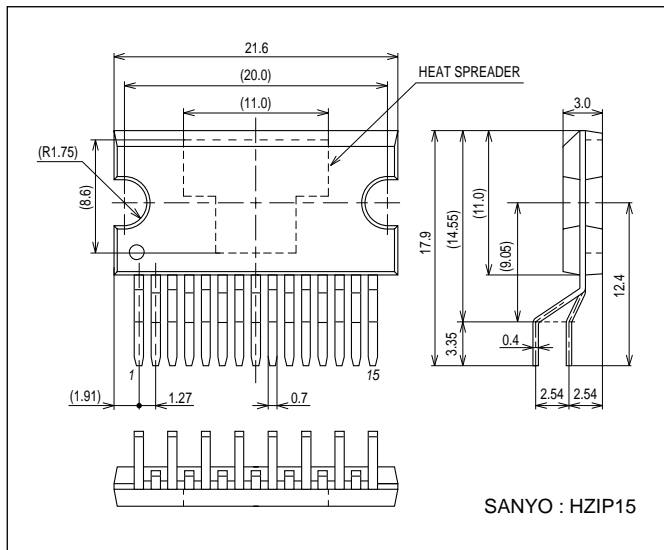

LA42105

Block Diagram

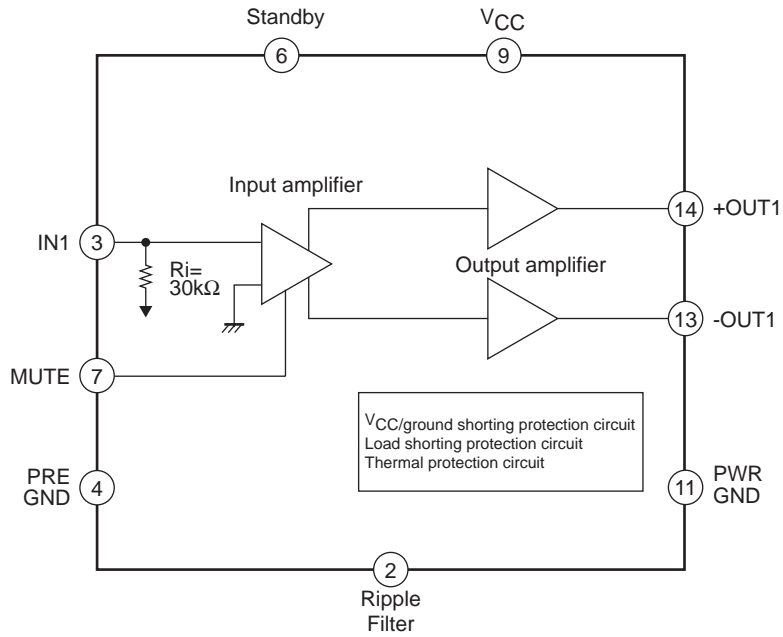

Test Circuit

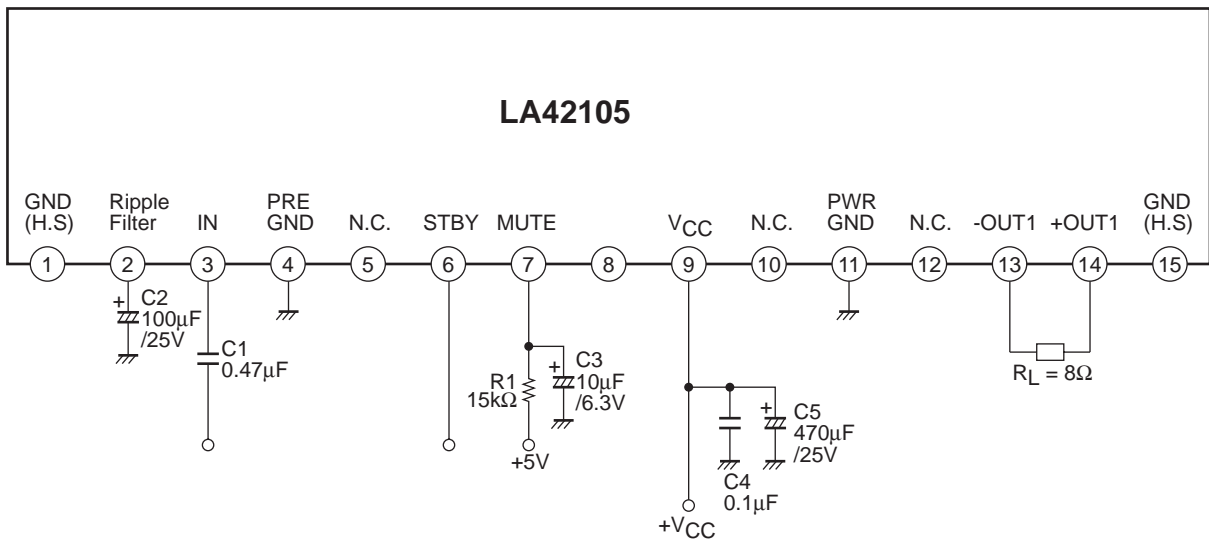

* Pin 8 : This pin must be left open.

* Pins 1 and 15 are connected to the heat sink. They must be connected to power and ground.

Pin Voltage

Conditions : $V_{CC} = 9.5V$, $STBY = 5V$

Pin No.	1	2	3	4	5	6	7	8	9	10	11	12	13	14	15
Pin	GND (H.S)	Ripple Filter	IN	Pre GND	N.C.	STBY	Mute	N.C.	V_{CC}	N.C.	Power GND	N.C.	-OUT1	+OUT1	GND (H.S)
Pin voltage (V)	0	9.2	0.7	0	-	5	0	-	9.5	-	0	-	4.8	4.8	0

External Components

- C1 : Input coupling capacitors. A value of $0.47\mu\text{F}$ is recommended.
The input pin potential is 0.7V .
- C2 : Capacitor which sets the starting time of the ripple filter and amplifier. A value of $100\mu\text{F}$ is recommended.
- C3, R1 : Capacitor and resistor for muting function. C3 is necessary even when the mute function is not used.
- C4 : This capacitor increases the oscillator margin. We recommend a value of $0.1\mu\text{F}$.
- C5 : Power supply capacitor.

1. Muting function (pin 7)

The muting function is turned on when the pin 7 voltage is 1.5V (minimum) or higher.

The V_M applied voltage is set so that the pin 7 voltage will be 1.5V or higher.

The muting time constant is determined by an C3, R1 circuit, and the component values must be determined by a careful analysis, since they are related to impulse noise that occurs when the muting function is turned on or off. Also note that since C3 affects the occurrence of impulse noise when the amplifier is turned on or off, it will be required if the muting function is not used.

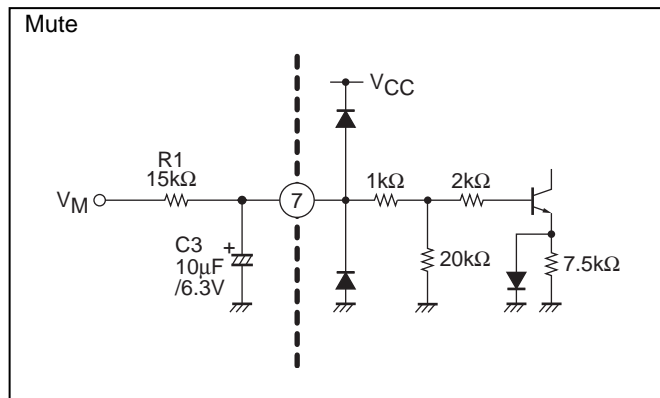

2. Standby function (pin 6)

The amplifier is turned on by applying a level of 2.5V (minimum) or higher to pin 6.

Pin 6 control voltage

Pin 6 voltage	Amplifier	Standby
0 to 0.5	Off	On
2.5 to V_{CC}	On	Off

The limit resistor R_{STB} may be inserted if the V_{STB} applied voltage is comparatively high and there is a need to suppress the pin 6 sink current.

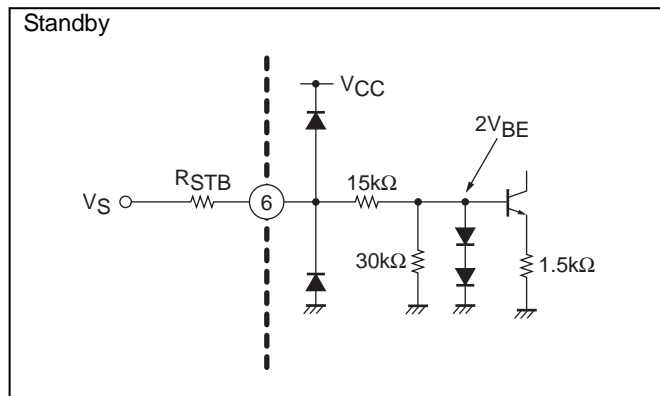

Usage Notes

1. This IC includes three short circuit protection circuits : shorting to power (shorts between an output and the power supply), shorting to ground (shorts between an output and ground), and load shorting protection circuits. These protection circuits operate while the corresponding abnormal condition continues, and recover automatically when the abnormal condition is resolved.
There are, however, cases where, due to IC usage conditions, one of these protection circuits may lock and continue operating after the problem has been resolved. If this occurs, the protection circuit state can be reset by either switching the IC to standby mode or by temporarily cutting power from the IC.
2. This IC includes a thermal protection circuit that operates if the junction temperature (T_j) rises to 160°C or higher. This circuit gradually reduces the output level.
3. If this IC is operated in the vicinity of any of its maximum ratings, even slight changes in operating conditions could result in a maximum rating being exceeded. Since this could lead to the destruction of the IC, end product designs must include adequate margins in the supply voltage and other parameters so that the IC is always used within ranges such that the maximum ratings are never exceeded.

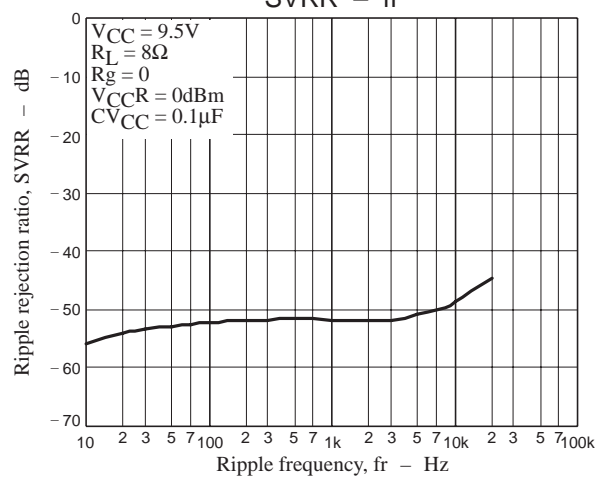
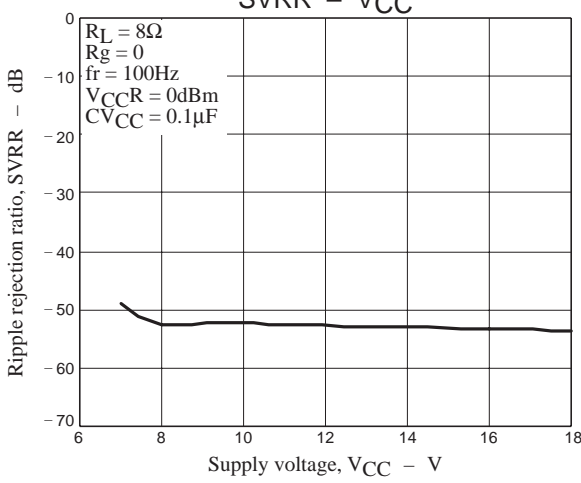
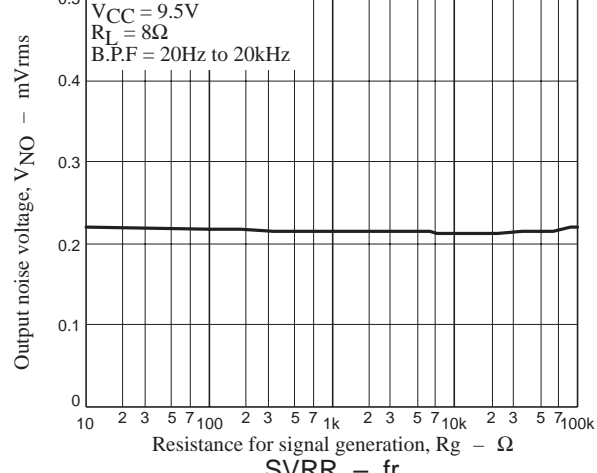
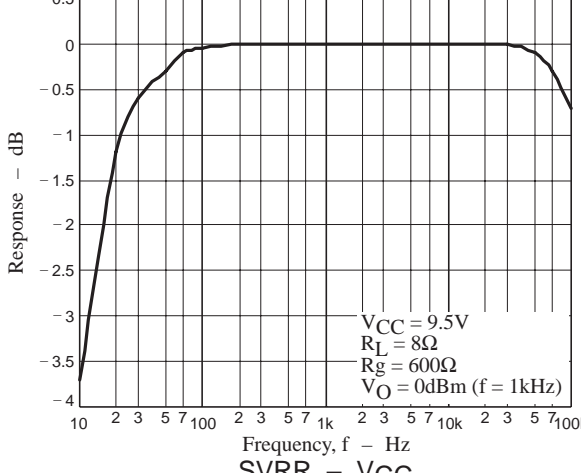
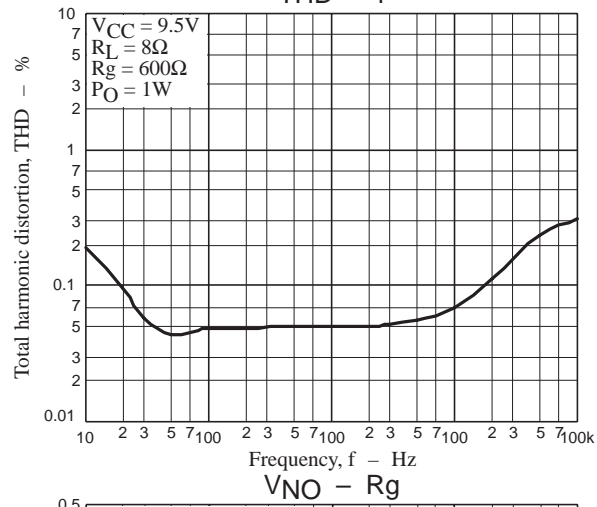
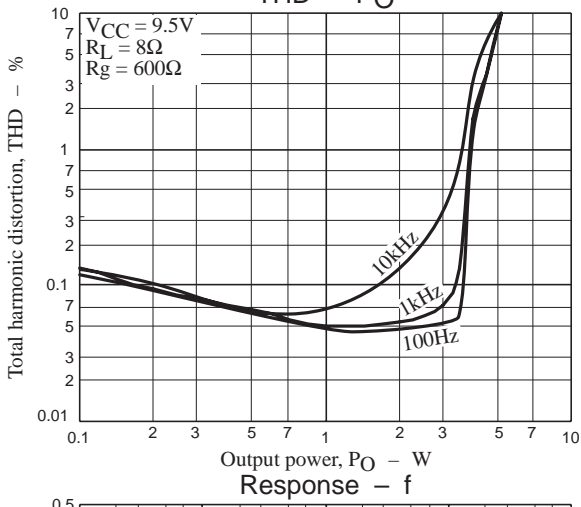
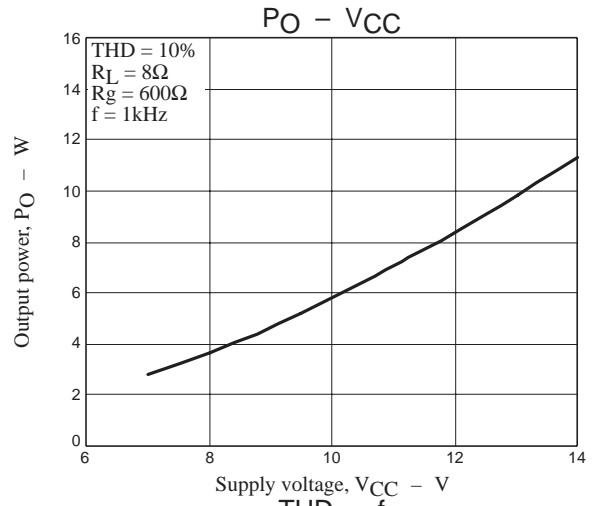
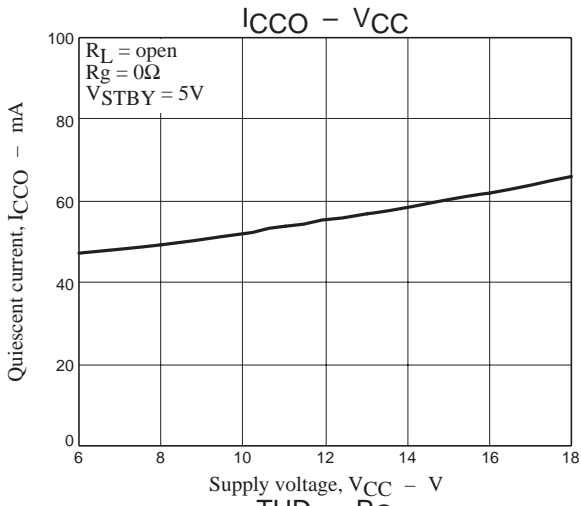

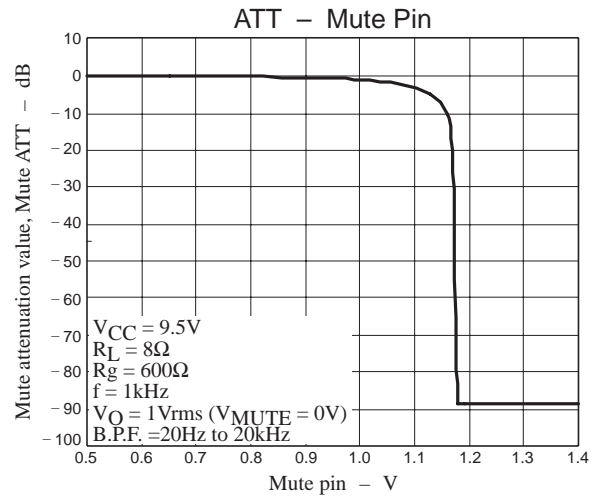
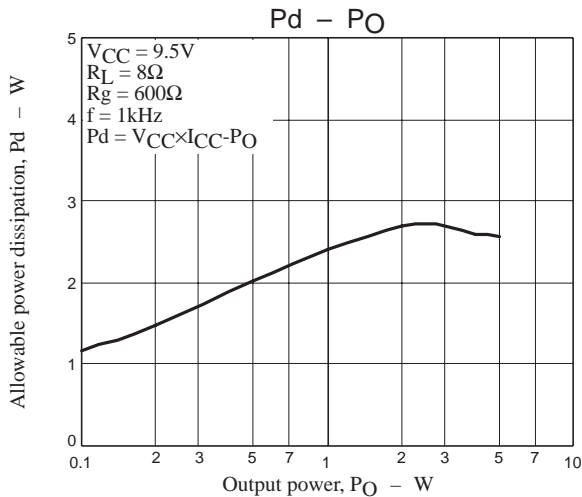

- SANYO Semiconductor Co.,Ltd. assumes no responsibility for equipment failures that result from using products at values that exceed, even momentarily, rated values (such as maximum ratings, operating condition ranges, or other parameters) listed in products specifications of any and all SANYO Semiconductor Co.,Ltd. products described or contained herein.
- SANYO Semiconductor Co.,Ltd. strives to supply high-quality high-reliability products, however, any and all semiconductor products fail or malfunction with some probability. It is possible that these probabilistic failures or malfunction could give rise to accidents or events that could endanger human lives, trouble that could give rise to smoke or fire, or accidents that could cause damage to other property. When designing equipment, adopt safety measures so that these kinds of accidents or events cannot occur. Such measures include but are not limited to protective circuits and error prevention circuits for safe design, redundant design, and structural design.
- In the event that any or all SANYO Semiconductor Co.,Ltd. products described or contained herein are controlled under any of applicable local export control laws and regulations, such products may require the export license from the authorities concerned in accordance with the above law.
- No part of this publication may be reproduced or transmitted in any form or by any means, electronic or mechanical, including photocopying and recording, or any information storage or retrieval system, or otherwise, without the prior written consent of SANYO Semiconductor Co.,Ltd.
- Any and all information described or contained herein are subject to change without notice due to product/technology improvement, etc. When designing equipment, refer to the "Delivery Specification" for the SANYO Semiconductor Co.,Ltd. product that you intend to use.
- Information (including circuit diagrams and circuit parameters) herein is for example only; it is not guaranteed for volume production.
- Upon using the technical information or products described herein, neither warranty nor license shall be granted with regard to intellectual property rights or any other rights of SANYO Semiconductor Co.,Ltd. or any third party. SANYO Semiconductor Co.,Ltd. shall not be liable for any claim or suits with regard to a third party's intellectual property rights which has resulted from the use of the technical information and products mentioned above.

This catalog provides information as of May, 2007. Specifications and information herein are subject to change without notice.