

## All-Digital High Efficiency Power Amplifiers

### FEATURES

- HIGH OUTPUT CAPABILITY
- **DDX® Mono-Mode:**
  - \* **DDX-2160:** 1 x 160 / 150 W, 3Ω / 4Ω, < 10% THD
  - \* **DDX-2120:** 1 x 125 / 150 W, 3Ω / 4Ω, < 10% THD
  - \* **DDX-2100:** 1 x 100 / 130 W, 3Ω / 4Ω, < 10% THD
- **DDX® Full-Bridge Mode:**
  - \* **DDX-2160:** 2 x 80 / 75 W, 6Ω / 8Ω, < 10% THD
  - \* **DDX-2120:** 2 x 62 / 75 W, 6Ω / 8Ω, < 10% THD
  - \* **DDX-2100:** 2 x 50 / 65 W, 6Ω / 8Ω, < 10% THD
- **Binary Half-Bridge Mode:**
  - \* **DDX-2160:** 4 x 40 W, 4Ω, < 10% THD
  - \* **DDX-2120:** 4 x 40 W, 4Ω, < 10% THD
  - \* **DDX-2100:** 4 x 32 W, 4Ω, < 10% THD
- SINGLE SUPPLY (+9V to +36V)
- COMPACT SURFACE MOUNT PACKAGE
- HIGH EFFICIENCY, > 88% @ 8 ohms
- THERMAL OVERLOAD PROTECTION
- SHORT CIRCUIT PROTECTION

### BENEFITS

- COMPLETE SURFACE MOUNT DESIGN
- POWER SUPPLY SAVINGS

### APPLICATIONS

- DIGITAL POWERED SPEAKERS
- PC SOUND CARDS
- CAR AUDIO
- SURROUND SOUND SYSTEMS
- DIGITAL AUDIO COMPONENTS

### 1.0 GENERAL DESCRIPTION

The DDX-2160, DDX-2120 and DDX-2100 power devices are monolithic, dual channel H-Bridges that can provide audio power up to:

- 80 watts per channel @10%THD, 6Ω (DDX-2160)
- 75 watts per channel @10%THD, 8Ω (DDX-2160, DDX-2120)
- 65 watts per channel @10%THD, 8Ω (DDX-2100)

at very high efficiency.

Each device contains a logic interface, integrated bridge drivers, high efficiency MOSFET output transistors and protection circuitry. Each device may be used in DDX® Mode as a dual bridge or reconfigured as a single bridge with double the output current capability. Alternatively, in Binary Mode, it may be configured as either a dual bridge or (at lower power output) a quad half-bridge or a combination of both types.

The benefits of the DDX® amplification system are: an all-digital design that eliminates the need for a digital to analog converter (DAC), and the high efficiency operation derived from the use of Apogee's patented damped ternary pulse width modulation (PWM). This approach provides an efficiency advantage over conventional PWM designs of more than three times the efficiency of typical Class A/B amplifiers with music input signals.

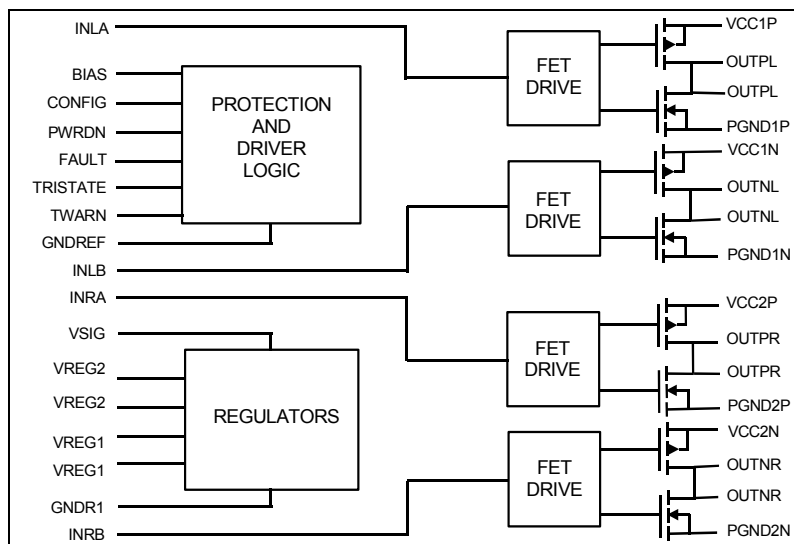

Figure 1. Block Diagram

Specifications are subject to change without notice.

## 1.1 Absolute Maximum Ratings [Note 1]

SYMBOL	PARAMETER	VALUE	UNIT
V <sub>CC</sub>	Power supply voltage	40	V
V <sub>L</sub>	Input logic reference	5.5	V
P <sub>TOT</sub>	Power Dissipation, T <sub>heat-spreader</sub> = 25°C [See Figure 4]	50	W
T <sub>j</sub>	Operating junction temperature range	0 to +150	°C
T <sub>stg</sub>	Storage temperature range	-40 to +150	°C

Note 1 - Permanent device damage may occur if ABSOLUTE MAXIMUM RATINGS are exceeded.  
Exposure to absolute maximum rating conditions for extended periods may affect device reliability.

## 1.2 Recommended Operating Conditions [Note 2]

SYMBOL	PARAMETER	MIN	TYP	MAX	UNIT
V <sub>CC</sub>	Power supply voltage	9.0		36.0	V
V <sub>L</sub>	Input logic reference	2.7	3.3	5.0	V
T <sub>A</sub>	Ambient Temperature	0		70	°C

Note 2 - Performance not guaranteed beyond recommended operating conditions.

## 1.3 Thermal Data

SYMBOL	PARAMETER	MIN	TYP	MAX	UNIT
θ <sub>J-C</sub>	Thermal resistance junction-case (heat spreader)			2.5	°C/W
T <sub>j-SD</sub>	Thermal shut-down junction temperature		150		°C
T <sub>WARN</sub>	Thermal warning temperature		130		°C
T <sub>hSD</sub>	Thermal shut-down hysteresis		25		°C

## 1.4 Electrical Characteristics. [Refer to circuit in Figure 17] Unless otherwise specified, performance is measured using the DDX-8001/DDX-8229 processor family, V<sub>CC</sub>=34V, V<sub>L</sub>=3.3V, f<sub>sw</sub>=384kHz, T<sub>C</sub>=25°C, R<sub>L</sub>=8Ω.

SYMBOL	PARAMETER	CONDITIONS			MIN	TYP	MAX	UNIT
		V <sub>CC</sub>	THD+N	R <sub>L</sub>				
P <sub>O-DM</sub> (DDX® Mono Mode) [Figure 19]	DDX-2160 – Power Per Channel [Note 3] [Note 4]	33V	<10%	3Ω	160			W <sub>RMS</sub>
			<1%		125			
	DDX-2160 - Power Per Channel [Note 3] [Note 5]	36V	<10%	4Ω		150		
			<1%			120		
	DDX-2120 – Power Per Channel [Note 3] [Note 4]	29V	<10%	3Ω	120			
	<1%		100					
DDX-2120 - Power Per Channel [Note 3] [Note 5]	36V	<10%	4Ω		150			
		<1%			120			
P <sub>O-DF</sub> (DDX® Full Bridge Mode) [Figure 17]	DDX-2160 - Power Per Channel [Note 4]	33V	<10%	6Ω	80			W <sub>RMS</sub>
			<1%		62			
	DDX-2160 - Power Per Channel [Note 5]	36V	<10%	8Ω		75		
			<1%			62		
	DDX-2120 - Power Per Channel [Note 4]	29V	<10%	6Ω	62			
	<1%		50					
DDX-2120 - Power Per Channel [Note 5]	36V	<10%	8Ω		75			
		<1%			62			
P <sub>O-Bin</sub> (Binary Half-Bridge Mode) [Figure 21]	DDX-2160 - Power Per Channel [Note 5]	36V	<10%	4Ω		40		W <sub>RMS</sub>
			<1%			30		
	DDX-2120 - Power Per Channel [Note 5]	36V	<10%	4Ω		40		
	<1%				30			
DDX-2100 - Power Per Channel [Note 4]	32V	<10%	4Ω	32				
		<1%		25				

Note 3 – Maximum power limited to < 1 second.

Note 4 – Power Output Limited by Minimum Current Limit.

Note 5 – Power Output Limited by Maximum Voltage Limit.

Specifications are subject to change without notice.

**1.4 Electrical Characteristics** (continued) [Refer to circuit in Figure 17] Unless otherwise specified, performance is measured using the DDX-8001/DDX-8229 processor family,  $V_{CC} = 34V$ ,  $V_L = 3.3V$ ,  $f_{sw} = 384kHz$ ,  $T_C = 25^\circ C$ ,  $R_L = 8\Omega$ .

SYMBOL	PARAMETER	CONDITION	MIN	TYP	MAX	UNIT
THD+N	Total Harmonic Distortion + Noise, [Note 6]	Po = 1 Wrms		0.04		%
		Po = 50 Wrms		0.13		
	Total Harmonic Distortion + Noise, [Note 7]	Po = 1 Wrms		0.08		
		Po = 50 Wrms		0.20		
SNR	Signal to Noise Ratio, DDX <sup>®</sup> Mode	A-Weighted		100		dB
	Signal to Noise Ratio, Binary Half-Bridge Mode, [Note 6]			92		
	Signal to Noise Ratio, Binary Half-Bridge Mode, [Note 7]			85		
$\eta$	Peak Efficiency, DDX <sup>®</sup> Mode	Po=2 x 50 W, 8 $\Omega$		88		%
	Peak Efficiency, Binary Half-Bridge Mode	Po=4 x 25 W, 4 $\Omega$		85		
I <sub>SC</sub>	Speaker Output Short-Circuit Protection Limit per Bridge [Note 8]	DDX-2160	4.5	6	8	A
		DDX-2120	4.0	6	8	
		DDX-2100	3.5	6	8	
R <sub>ds-on</sub>	Power MOSFET output resistance	I <sub>d</sub> =1A		200	270	m $\Omega$
g <sub>N</sub>	Power Nchannel R <sub>ds-on</sub> matching	I <sub>d</sub> = 1A	95			%
g <sub>P</sub>	Power Pchannel R <sub>ds-on</sub> matching	I <sub>d</sub> = 1A	95			%
I <sub>dss</sub>	Power Pchannel/Nchannel leakage	V <sub>CC</sub> = 35 V			50	$\mu$ A
UVL	Under-voltage Lockout Threshold			7	9	V
I <sub>PD</sub>	V <sub>CC</sub> supply current, Power-down	PWRDN = 0		1	3	mA
I <sub>CC-tri</sub>	V <sub>CC</sub> supply current, Tri-state	TRISTATE = 0		22		mA
I <sub>CC</sub>	DDX <sup>®</sup> mode V <sub>CC</sub> supply current	2-Channel switching at 384kHz.		86		mA
	Binary mode V <sub>CC</sub> supply current	4-Channel switching at 384kHz.		103		
t <sub>on</sub>	Turn-on delay time	Resistive load			100	ns
t <sub>off</sub>	Turn-off delay time	Resistive load			100	ns
t <sub>r</sub>	Rise time	Resistive load			25	ns
t <sub>f</sub>	Fall Time	Resistive load			25	ns
V <sub>IL</sub>	Low logic input voltage: PWRDN, TRISTATE pins	V <sub>L</sub> = 2.7V	0.7			V
		V <sub>L</sub> = 3.3V	0.8			
		V <sub>L</sub> = 5.0V	0.85			
	Low logic input voltage: INLA, INLB, INRA, INRB pins	V <sub>L</sub> = 2.7V	1.05			
V <sub>L</sub> = 3.3V		1.35				
V <sub>L</sub> = 5.0V		2.2				
V <sub>IH</sub>	High logic input voltage: PWRDN, TRISTATE pins	V <sub>L</sub> = 2.7V			1.5	V
		V <sub>L</sub> = 3.3V			1.7	
		V <sub>L</sub> = 5.0V			1.85	
	High logic input voltage: INLA, INLB, INRA, INRB pins	V <sub>L</sub> = 2.7V			1.65	
V <sub>L</sub> = 3.3V				1.95		
V <sub>L</sub> = 5.0V				2.8		
I <sub>fault</sub>	Output Sink Current, FAULT, TWARN pins	Fault Active		1		mA
P <sub>Wmin</sub>	Minimum output pulse width	No load	70		150	ns

Note 6 – Performance Characteristics obtained using a DDX-8001/DDX-8229 controller.

Note 7 - Performance Characteristics obtained using a DDX-8000/DDX-8228 controller.

Note 8 – If used in single BTL (Mono Mode) configuration, the device may not be short-circuit protected.

**Specifications are subject to change without notice.**

## 1.5 Logic Truth Table

TRISTATE	INxA	INxB	OUTPx	OUTNx	OUTPUT MODE
0	X	X	OFF	OFF	Hi-Z
1	0	0	GND	GND	DAMPED
1	0	1	GND	VCC	NEGATIVE
1	1	0	VCC	GND	POSITIVE
1	1	1	VCC	VCC	Not Used

## 2.0 DDX-2160, DDX-2120 and DDX-2100 Pin Function Description:

### 2.1 PWM Inputs

	Pin No.	Description
INLA	29	Left A logic input signal
INLB	30	Left B logic input signal
INRA	31	Right A logic input signal
INRB	32	Right B logic input signal

### 2.2 Control/Miscellaneous

Pin Name	Pin No.	Description
PWRDN	25	Power Down (0=Shutdown, 1= Normal).
TRI-STATE	26	Tri-State (0=All MOSFETS Hi-Z, 1=Normal).
FAULT [Note 9]	27	Fault output indicator; Overcurrent, Overvoltage or Overtemperature (0=Fault, 1=Normal).
TWARN [Note 9]	28	Thermal warning output (0=Warning $T_J \geq 130^\circ\text{C}$ , 1=Normal).
CONFIG [Note 10]	24	Configuration (0=Normal, 1=Parallel operation for mono).
NC	18	Do not connect.

Note 9: FAULT and TWARN outputs are open-drain

Note 10: Connect CONFIG Pin 24 to VREG1 Pins 21, 22 to implement single bridge (mono mode) operation for high current.

### 2.3 Power Outputs for DDX<sup>®</sup> Mode or Binary Full Bridge Mode [Note 11]

Pin Name	Pin No.	Description
OUTPL	16, 17	Left output, positive reference
OUTNL	10, 11	Left output, negative reference
OUTPR	8, 9	Right output, positive reference
OUTNR	2, 3	Right output, negative reference

Note 11: DDX<sup>®</sup> outputs are bridged. The outputs OUTPx produce signals in phase with the input.

### 2.4 Power Outputs for Binary Half-Bridge Mode [Note 12]

Pin Name	Pin No.	Description
OUTNR	2, 3	CH4 output, positive reference
OUTPR	8, 9	CH3 output, positive reference
OUTNL	10, 11	CH2 output, positive reference
OUTPL	16, 17	CH1 output, positive reference

Note 12: Half-Bridge Binary Mode outputs are NOT bridged. All outputs produce signals in phase with the input.

Specifications are subject to change without notice.

**2.5 Power Supplies**

Pin Name	Pin No.	Description
VCC [1P, 1N, 2P, 2N]	4, 7, 12, 15	Power
PGND [1P, 1N, 2P, 2N]	5, 6, 13, 14	Power grounds
VREG1	21, 22	Internal regulator voltage requires bypass capacitor.
VREG2	33, 34	Internal regulator voltage requires bypass capacitor.
VSIG	35, 36	Signal Positive supply.
VL [Note 13]	23	Logic reference voltage.
GNDREF	19	Logic reference ground.
GNDS	1	Substrate ground.
GNDR1	20	Internal regulator ground.

*Note 13:  $V_L$  (Logic Reference Voltage) is recommended to be powered and stable prior to  $V_{cc}$  achieving > 7V to assure proper power up sequence.  $V_L$  is recommended to remain powered and stable until after  $V_{cc}$  has decayed below 7V during power removal.*

**Specifications are subject to change without notice.**

### 3.0 DDX-2160, DDX-2120 and DDX-2100 POWER DEVICES

The DDX-2160, DDX-2120 and DDX-2100 Power Devices are dual channel H-Bridges that can deliver more than 80/75/65 watts per channel (<10%THD) of audio output power at very high efficiency. They convert both DDX<sup>®</sup> and binary-controlled PWM signals into audio power at the load. Each includes a logic interface, integrated bridge drivers, high efficiency MOSFET outputs, and thermal and short circuit protection circuitry. In DDX<sup>®</sup> mode, two logic level signals per channel are used to control high-speed MOSFET switches to connect the speaker load to the input supply or to ground in a bridge configuration, according to Apogee's patented damped ternary PWM. In Binary Mode operation, both Full Bridge and Half Bridge Modes are supported. These devices include over-current and thermal protection as well as under-voltage lockout with automatic recovery. A thermal warning status is also provided.

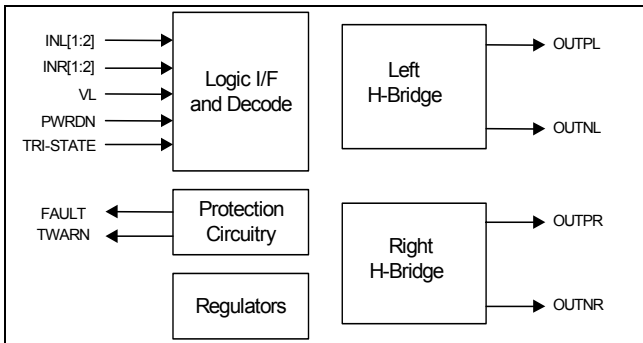

Figure 2 - DDX-2160, DDX-2120 and DDX-2100 Block Diagram, Full-Bridge DDX<sup>®</sup> or Binary Modes

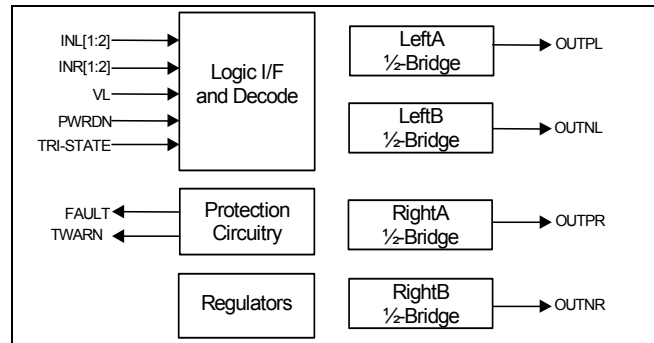

Figure 3 - DDX-2160, DDX-2120 and DDX-2100 Block Diagram, Binary Half-Bridge Mode

#### 3.1 Logic Interface and Decode

The DDX-2160, DDX-2120 and DDX-2100 power outputs are controlled using one or two logic level timing signals. In order to provide a proper logic interface, the V<sub>L</sub> input must operate at the same voltage as the DDX<sup>®</sup> controller logic supply. V<sub>L</sub> (Logic Reference Voltage) is recommended to be powered and stable prior to V<sub>cc</sub> achieving > 7V to assure proper power up sequence. V<sub>L</sub> is recommended to remain powered and stable until after V<sub>cc</sub> has decayed below 7V during power removal.

#### 3.2 Protection Circuitry

The DDX-2160, DDX-2120 and DDX-2100 include protection circuitry for over-current and thermal overload conditions. A thermal warning pin TWARN is activated low (open-drain MOSFET) when the IC temperature exceeds 130°C, in advance of the thermal shutdown protection. When a fault condition is detected (logical OR of over-current and thermal), an internal fault signal acts to immediately disable the output power MOSFETs, placing both H-bridges in a high impedance state. At the same time an open-drain MOSFET connected to the FAULT pin is switched on.

There are two possible modes subsequent to activating a fault. The first is a SHUTDOWN mode. With FAULT (pull-up resistor) and TRI-STATE pins independent, an activated fault will disable the device, signaling low at the FAULT output. The device may subsequently be reset to normal operation by toggling the TRI-STATE pin from High to Low to High using an external logic signal.

The second is an AUTOMATIC recovery mode. This is depicted in the application circuit in Figure 17. The FAULT and TRI-STATE pins are shorted together and connected to a time constant circuit comprising R<sub>T</sub> and C<sub>T</sub>. An activated FAULT will force a reset on the TRI-STATE pin causing normal

Specifications are subject to change without notice.

operation to resume following a delay determined by the time constant of the circuit. If the fault condition is still presented, the circuit operation will continue repeating until such time as the fault condition is removed. An increase in the time constant of the circuit will produce a longer recovery interval. Care must be taken in the overall system design so as not to exceed the protection thresholds under normal operation.

### 3.3 Power Outputs

The DDX-2160, DDX-2120 and DDX-2100 power and output pins are duplicated to provide a low impedance path for the device's bridged outputs. All duplicate power, ground and output pins must be connected for proper operation. The PWRDN or TRI-STATE pins should be used to set all MOSFETS to the Hi-Z state during power-up until the logic power supply,  $V_L$ , is settled.

### 3.4 Parallel Output/High Current Operation

When using DDX<sup>®</sup> Mode output, the DDX-2160, DDX-2120 and DDX-2100 outputs can be connected in parallel to increase the output current to a load. In this configuration the devices can provide over 160W@3Ω / 150W@4Ω / 130W@4Ω (see Figure 6). This mode is enabled with the CONFIG pin connected to VREG1 and the inputs combined INLA = INLB, INRA = INRB and outputs combined OUTLA = OUTLB, OUTRA = OUTRB.

### 3.5 ADDITIONAL INFORMATION

#### 3.6 Output Filter

A passive two-pole low-pass filter is used on the DDX-2160, DDX-2120 and DDX-2100 power outputs to reconstruct an analog signal. System performance can be significantly affected by the output filter design and choice of components. (See appnote: [AN-15, Component Selection for DDX Amplifiers](#).) A filter design for 6Ω/8Ω loads is shown in the Typical Application Circuit in Figure 17. Figure 19 shows a filter design for 4Ω loads. Figure 23 shows a filter for ½ bridge mode, 4Ω loads.

#### 3.7 Power Dissipation & Heat Sink Requirements

The power dissipated within the device will depend primarily on the supply voltage, load impedance, and output modulation level.

The surface mount package of the DDX-2160, DDX-2120 and DDX-2100 include an exposed thermal slug on the top of the device to provide a direct thermal path from the integrated circuit to the heatsink. Careful consideration must be given to the overall thermal design. See Figure 4 for power derating.

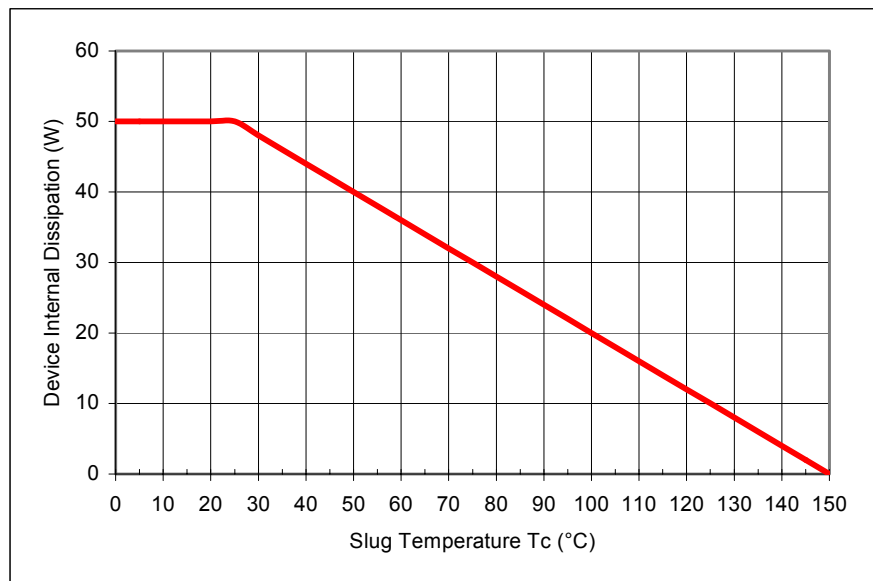

Figure 4 –Power Derating Curve (Typical)

Specifications are subject to change without notice.

For additional thermal design considerations, see: [AN19, Power Device Thermal Calculator](#).

For additional design considerations with binary mode operation, see application note: [AN-16, Applying the DDX-8000/DDX-8228 in Binary Mode](#).

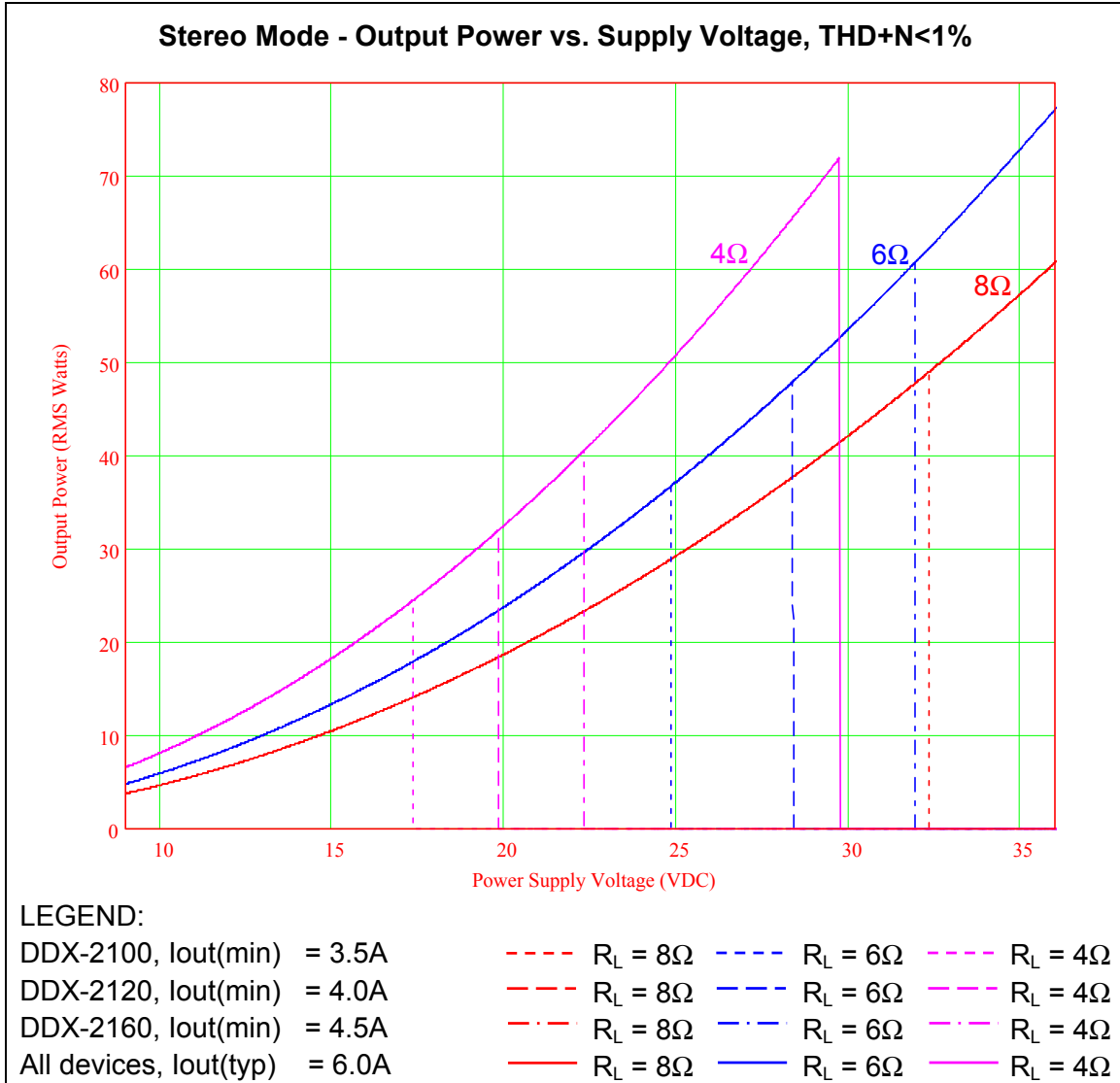

Figure 5. Output Power vs. Supply Voltage for Stereo Bridge.

Figure 5 shows the full-scale output power (0dB FS digital input with unity amplifier gain) as a function of Power Supply Voltage for 4, 6, and 8 Ohm loads in either DDX<sup>®</sup> Mode or Binary Full Bridge Mode. Output power is constrained for higher impedance loads by the maximum voltage limit of the DDX-2160, DDX-2120 and DDX-2100 ICs and by the over-current protection limit for lower impedance loads. The minimum threshold for the over-current protection circuit is 4.5/4.0/3.5A (at 25 °C) but the typical threshold is 6A. Solid curves depict typical output power capability of each device. Dotted and dashed curves depict the output power capability constrained to the minimum current specification of for the DDX-2100, DDX-2120 and DDX-2160 respectively. The output power curves assume proper thermal management of the power device's internal dissipation. See Figure 4.

**NOTE: Output power at 10% THD is approximately 30% higher.**

**Specifications are subject to change without notice.**



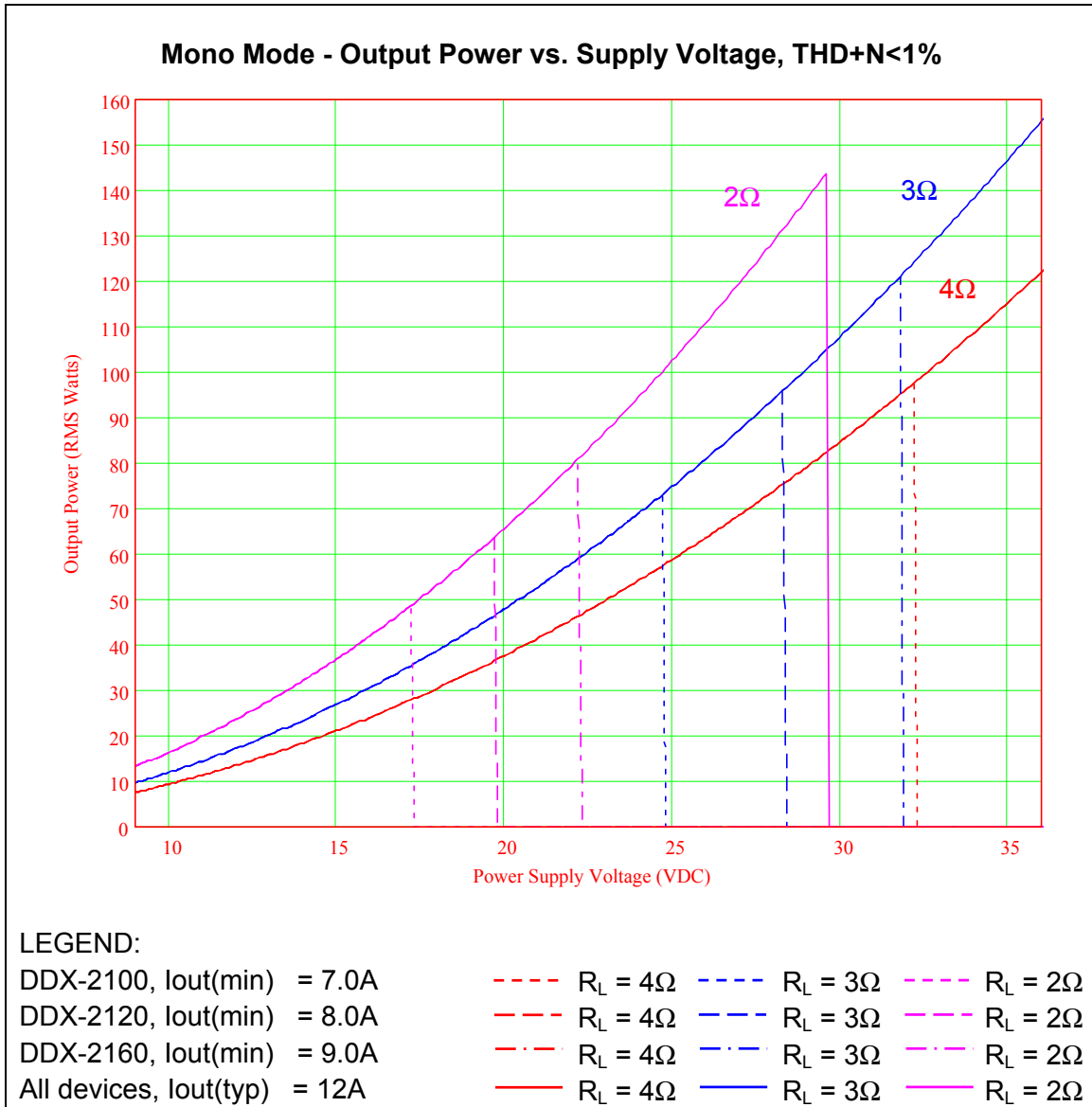

Figure 6. Mono Bridge Output, DDX® Mode Only, Power vs Supply <1% THD.

Figure 6 depicts the mono mode output power as a function of power supply voltages for loads of 2, 3, and 4 Ohms. The same current limit observations from Figure 5 apply, except output current is 9A/8A/7A minimum, 12A typical in mono bridge configuration. Solid curves depict typical performance and dotted and dashed curves depict the minimum current limit for the DDX-2100, DDX-2120 and DDX-2160 respectively. Again, the output power curves assume proper thermal management of the power device's internal dissipation.

**NOTE: Output power at 10% THD is approximately 30% higher.**

**Specifications are subject to change without notice.**

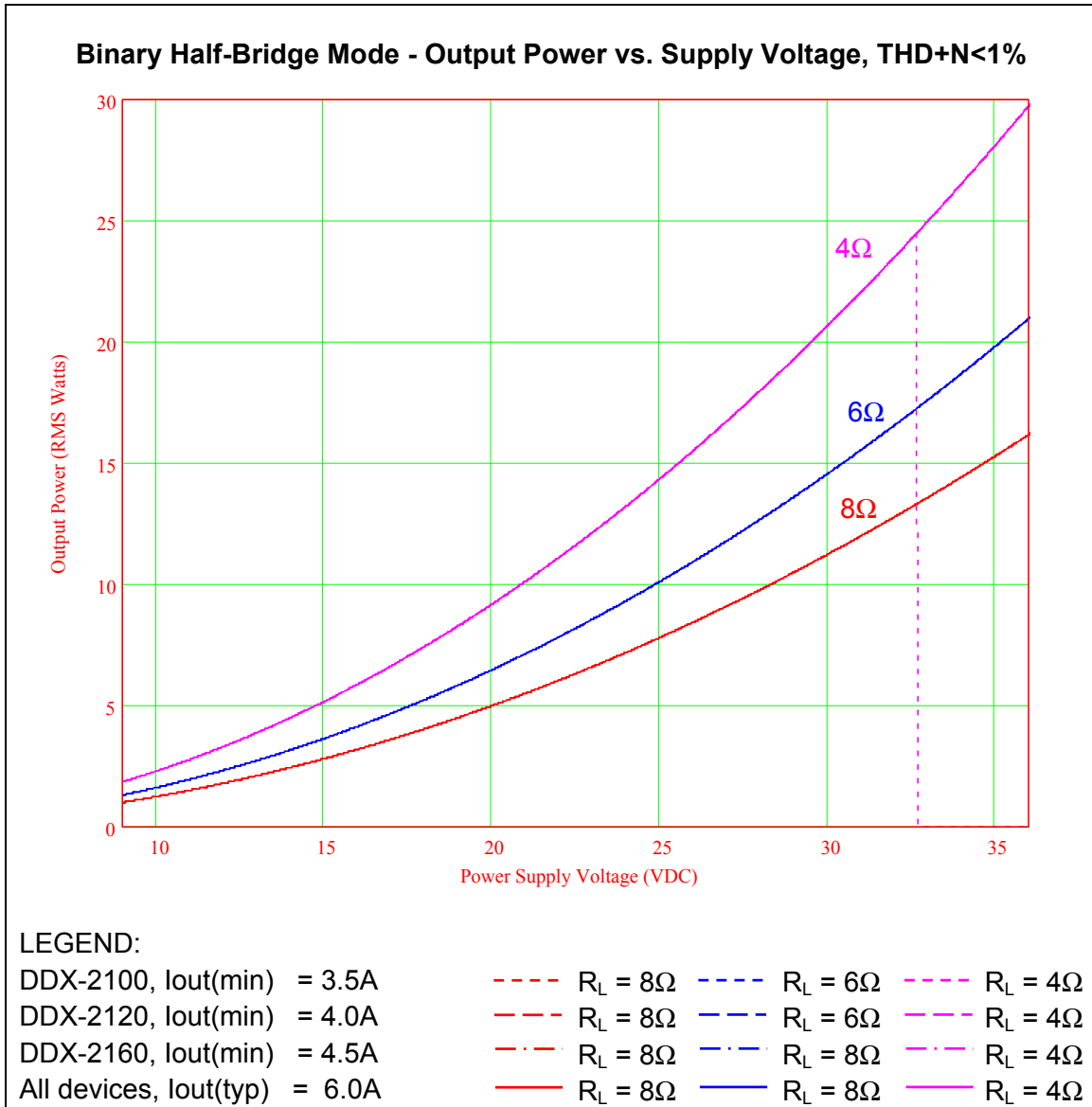

Figure 7. Half-Bridge Binary Mode Output Power vs Supply <1% THD  
(NOTE: Curves taken at  $f = 1$  kHz and using a 330uF blocking capacitor.)

Figure 7 depicts the output power as a function of power supply voltages for loads of 4, 6, and 8 Ohms when the DDX-2160, DDX-2120 and DDX-2100 are operated in a half-bridge Binary Mode. Solid curves depict typical performance and dotted and dashed curves depict the minimum current limit for the DDX-2100, DDX-2120 and DDX-2160 respectively. Once again, the output power curves assume proper thermal management of the power device's internal dissipation.

**NOTE: Output power at 10% THD is approximately 30% higher.**

Specifications are subject to change without notice.

**3.8 Typical Stereo Mode Performance Characteristics.**

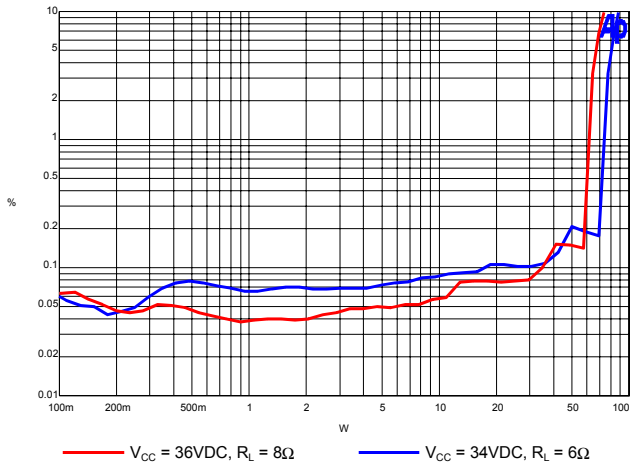

Figure 8. THD+N vs. Output Power @ 1kHz, using a DDX-8001 controller

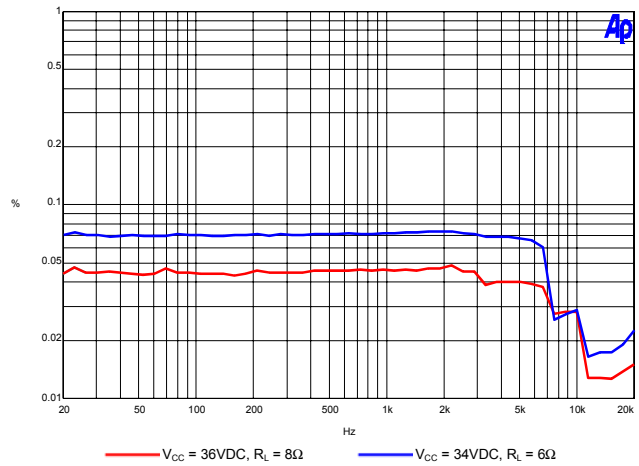

Figure 9. THD+N vs. Frequency, 1W, using a DDX-8001 controller

**3.9 Typical Mono Mode Performance Characteristics.**

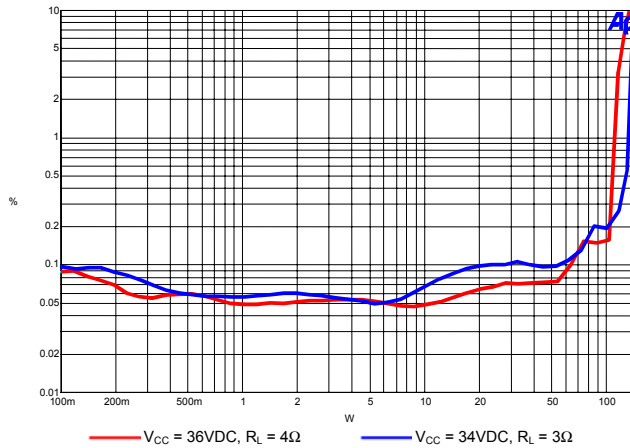

Figure 10. THD+N vs. Output Power @ 1kHz

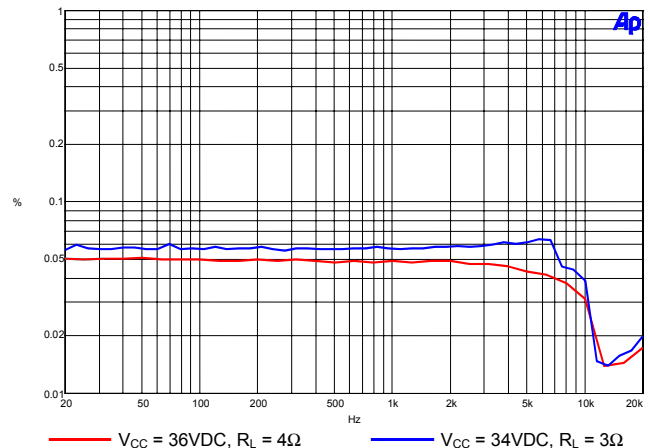

Figure 11. THD+N vs. Frequency, 1W

Specifications are subject to change without notice.

**3.10 Typical Binary Half-Bridge Mode Performance Characteristics,  $V_{CC} = 36\text{ VDC}$ ,  $R_L = 4\Omega$ .**

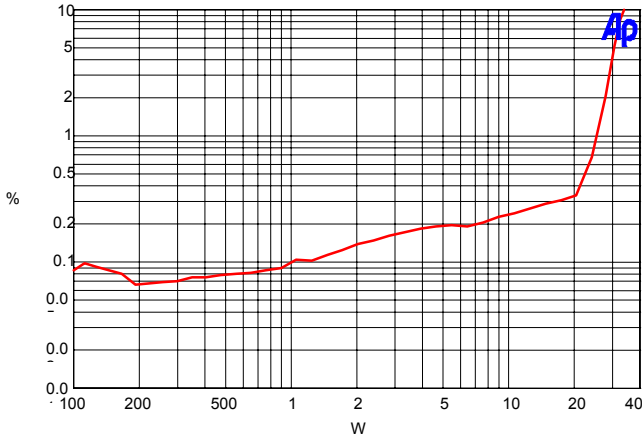

Figure 12. THD+N vs. Output Power @ 1kHz

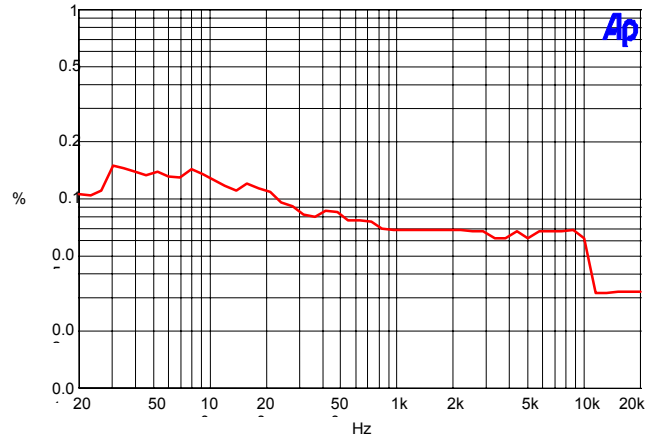

Figure 13. THD+N vs. Frequency, 1W

**3.11 Typical DDX-Mode Performance Characteristics at  $V_{CC} = 36\text{V}$ ,  $8\Omega$  Load,  $<1\%$  THD+N.**

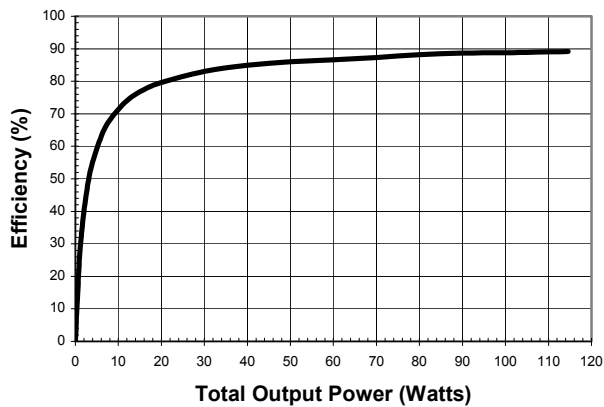

Figure 14. Typical Efficiency vs. Power

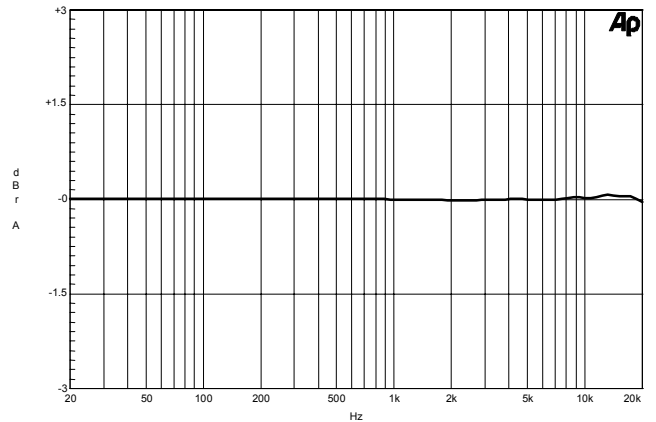

Figure 15. Typical Frequency Response

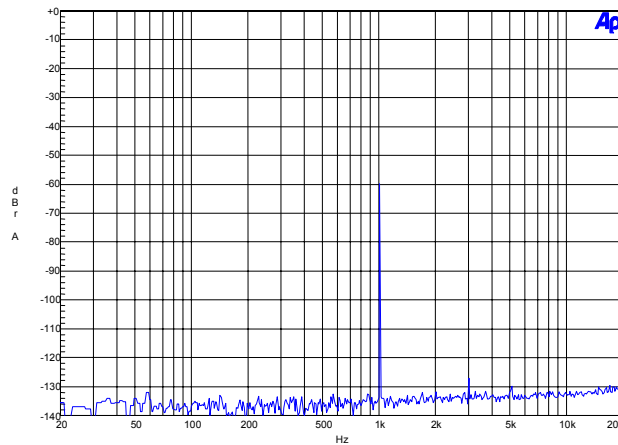

Figure 16. Typical FFT @ -60 dB, using a DDX-8001 controller

**Specifications are subject to change without notice.**

**4.0 APPLICATION REFERENCE DESIGNS.**

Apogee can provide reference designs for most applications.  
Contact Apogee Technical Support for more information.

**4.1 STEREO MODE**

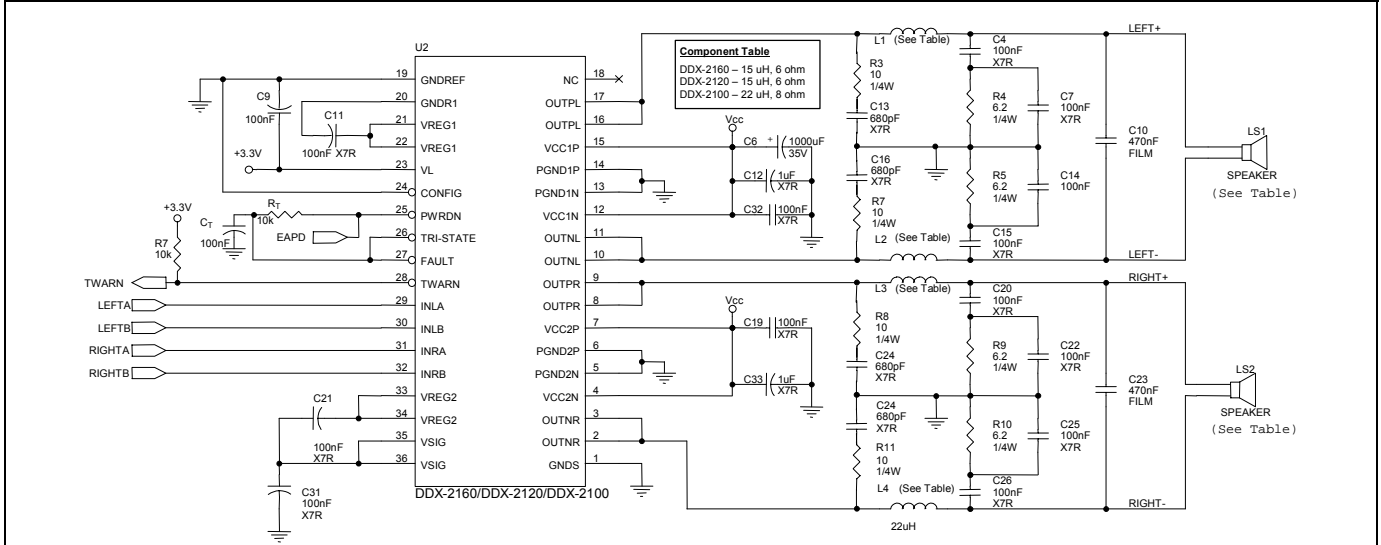

Figure 17. DDX® Stereo Mode Audio Application Circuit

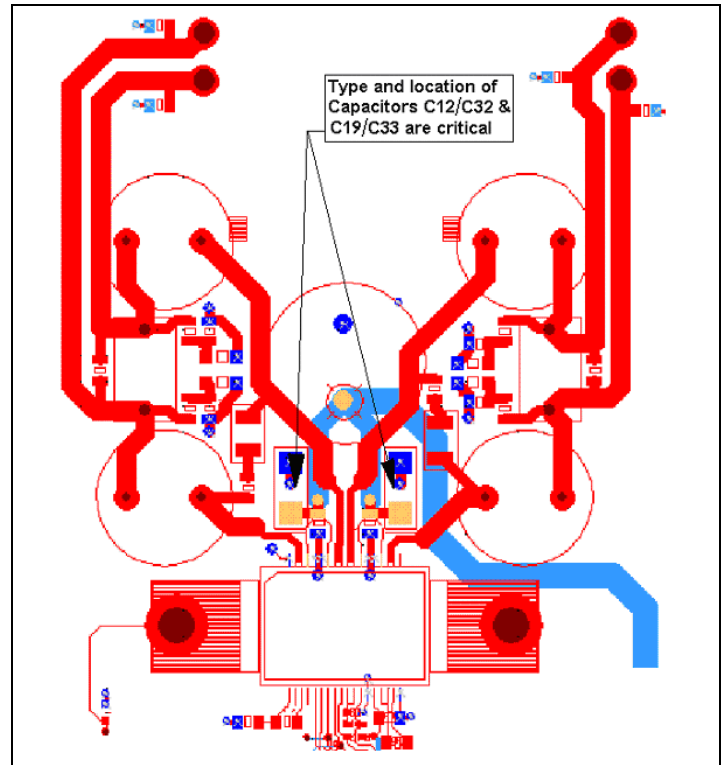

Figure 18 - Sample DDX® Stereo Mode Layout

Specifications are subject to change without notice.

**4.2 MONO MODE.**

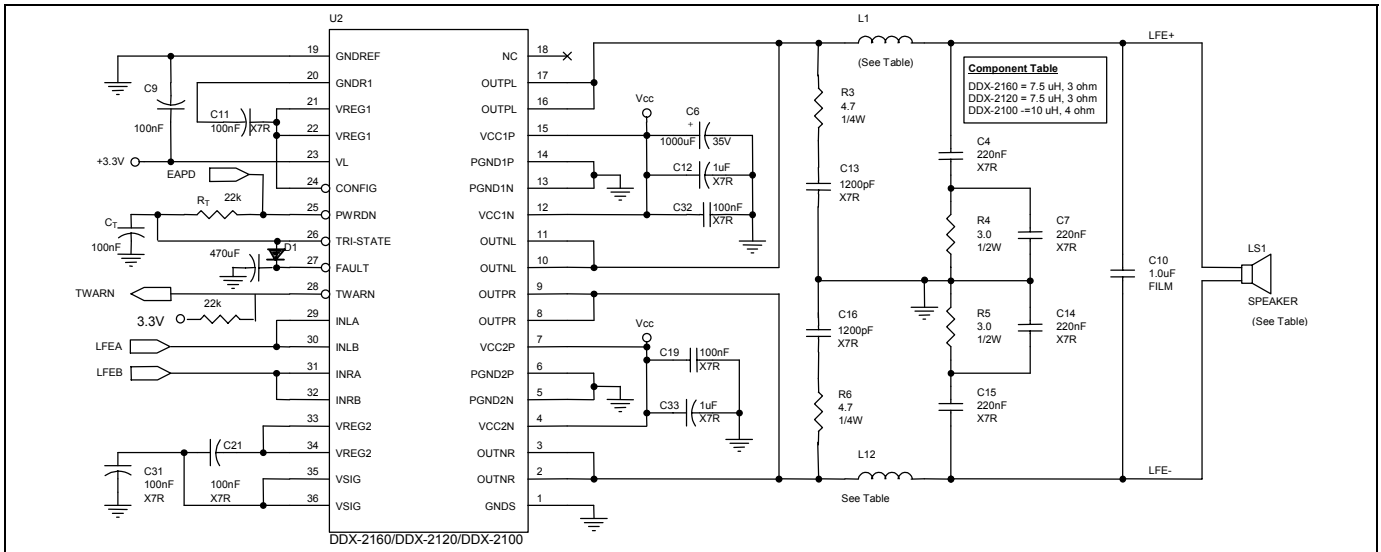

Figure 19. DDX® Mono Mode Audio Application Circuit

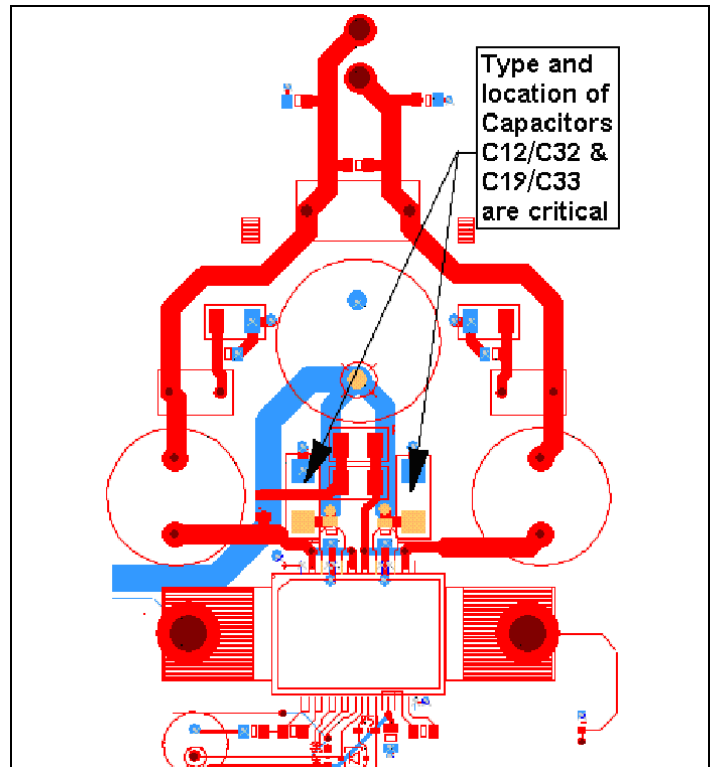

Figure 20 – Sample DDX® Mono Mode Layout

**Specifications are subject to change without notice.**

**4.3 BINARY MODE, 2.1 CHANNEL.**

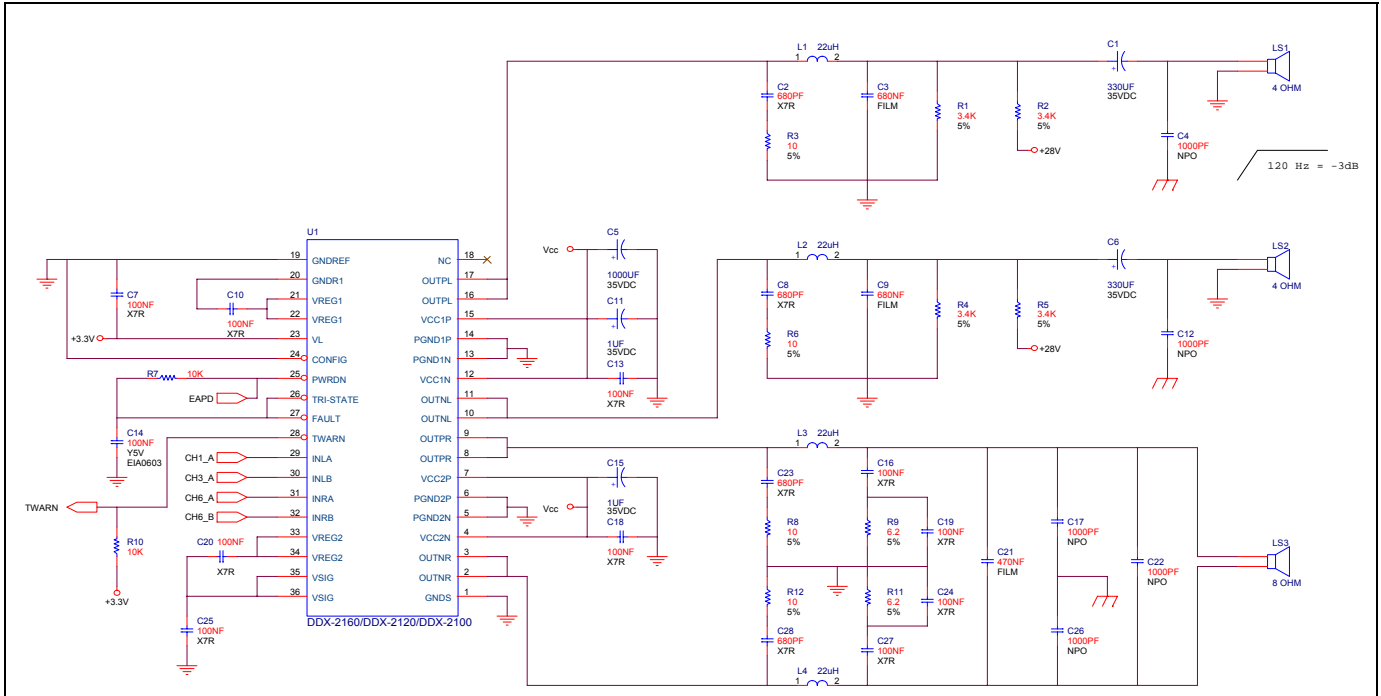

Figure 21 Binary Mode, 2.1 Channel Audio Application Circuit (See Note 14)

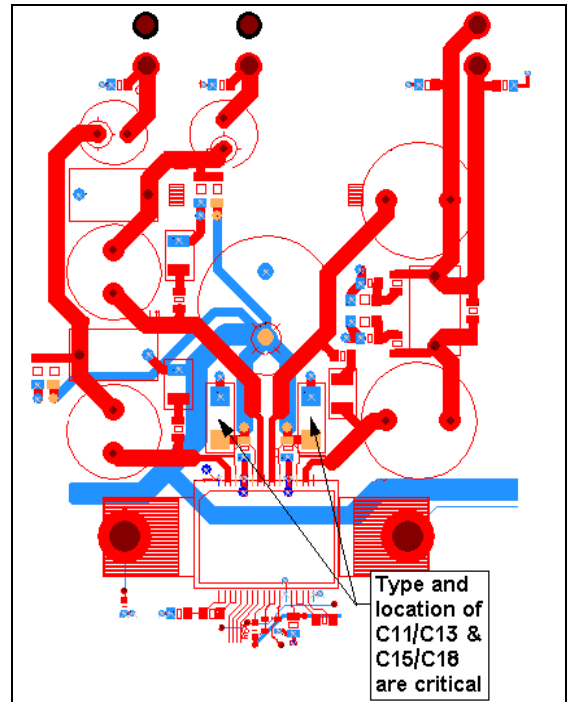

Figure 22 – Sample Binary Mode, 2.1 Channel Layout

Specifications are subject to change without notice.

**4.4 BINARY MODE, 4 CHANNEL.**

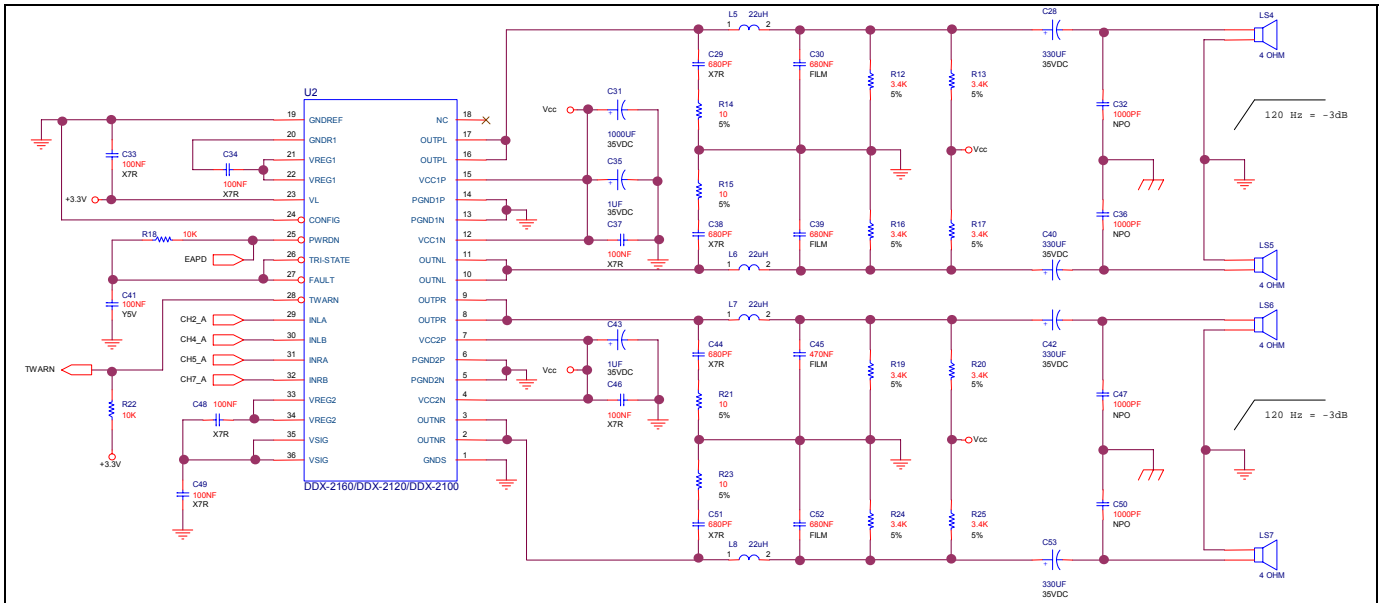

Figure 23. Binary Mode, 4-Channel Audio Application Circuit (See Note 14)

Note 14: Channel mappings in Binary mode schematics apply to DDX-8000/DDX-8228 PWM output channels.

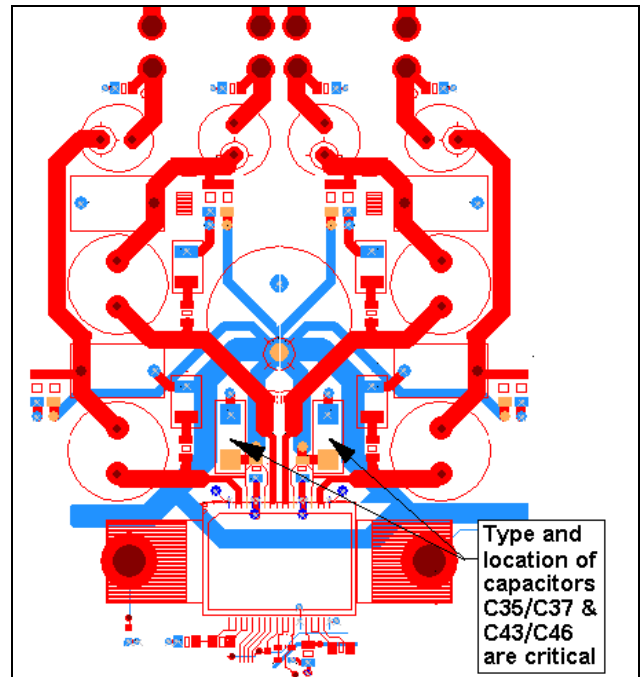
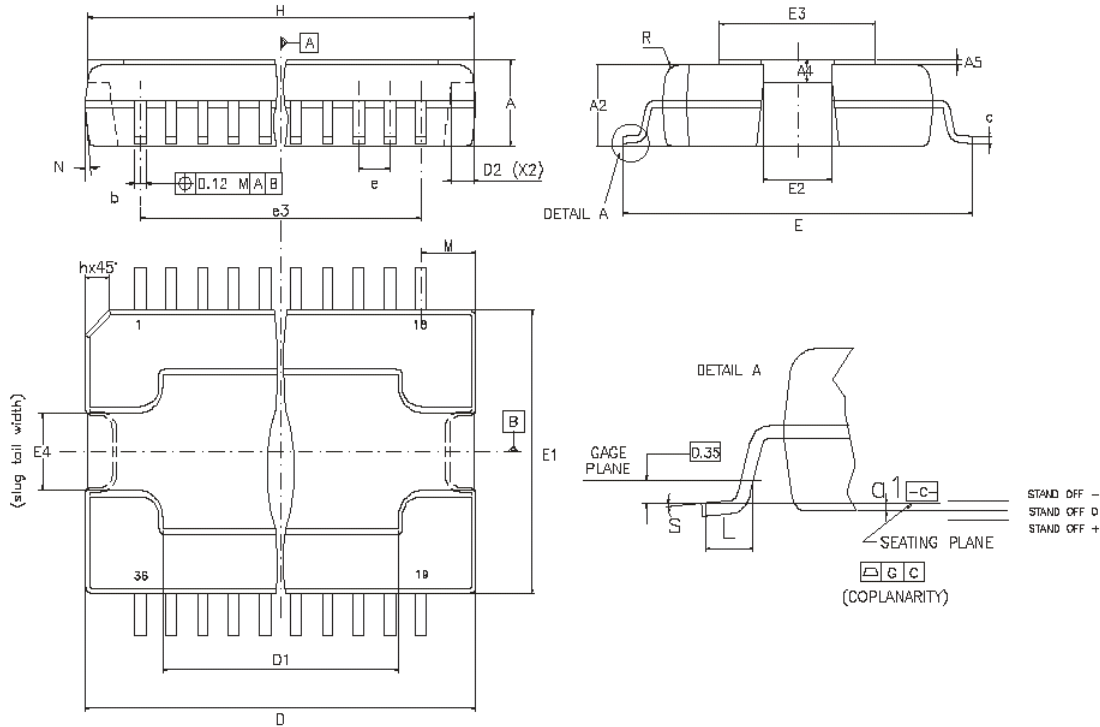

Figure 24 – Sample Binary Mode, 4 Channel Layout

Specifications are subject to change without notice.



## PHYSICAL DIMENSIONS (Dimensions shown in mm)



12

7182021

Reference Dimension	DATA BOOK mm			DATA BOOK inc		
	TYP	MIN	MAX	TYP	MIN	MAX
A	-	3.25	3.5		0.128	0.138
A2	-	-	3.3			0.130
A4	-	0.8	1		0.032	0.039
A5	0.2	-	-	0.008		
a1	-	0.030	-0.040		0.001	-0.002
b	-	0.22	0.38	0.000	0.009	0.015
c	-	0.23	0.32		0.009	0.013
D	-	15.80	16.00		0.623	0.631
D1	-	9.40	9.80		0.371	0.386
D2	1	-	-	0.039		
E	-	13.9	14.5		0.548	0.572
E1	-	10.9	11.1		0.430	0.438
E2	-	-	2.9			0.114
E3	-	5.8	6.2		0.229	0.244
E4	-	2.9	3.2		0.114	0.126
e	0.65	-	-	0.026		
e3	11.05	-	-	0.436		
G	-	0	0.075		0.000	0.003
H	-	15.5	15.9		0.611	0.627
h	-	-	1.1			0.043
L	-	0.8	1.1		0.032	0.043
M	-	-	-			
N	-	-	10deg			
R	-	-	-			
s	-	-	8deg			

- 1: "D" and "E1" do not include mold flash or protrusions  
Mold flash or protrusions shall not exceed 0.15 mm (0.006") per side
- 2: No intrusion allowed inwards the leads

Information furnished in this publication is believed to be accurate and reliable. However, Apogee Technology, Inc. assumes no responsibility for its use, or for any infringements of patents or other rights of third parties that may result from its use. Specifications in this publication are subject to change without notice. This publication supersedes and replaces all information previously supplied.

© Apogee Technology, Inc. All Rights Reserved

**Specifications are subject to change without notice.**